

**PREMACINATORI MONOALBERO serie PMG**

La nuova serie di premacinatori GUIDETTI ad "ALTA EFFICIENZA DI TAGLIO", grazie alle varie combinazioni possibili tra potenza, diametro griglia, separazione magnetica, ecc. possono lavorare molti materiali: cavi di rame o alluminio, metalli non ferrosi, gomma, materie plastiche, legno, materiali compositi, carta, ecc. con produzioni variabili da 300 a 3.000 kg/h. Per rimuovere le parti ferrose e proteggere i taglienti nelle successive operazioni di macinazione il sistema ideale è il trasportatore GUIDETTI con separatore magnetico a rullo o overband magnetico, disponibile in diverse dimensioni standard oppure in base alle esigenze del cliente.

**SINGLE-SHAFT PRE-SHREDDERS series "PMG"**

Guidetti's new series of pre-shredders, characterized by "HIGH CUTTING EFFICIENCY", thanks to the various combinations of power, screen-size, magnetic separation, etc, can process different kinds of materials: electric cables with either copper or aluminium, non-ferrous metals, rubber, plastic materials, wood, composite materials, paper etc. The production capacity ranges from 300 to 3000 kg/h. Also Guidetti introduces its new conveyor belt equipped with magnetic pulley or magnetic overband, the ideal solution to remove iron parts and to avoid damages during further grinding processes. It is available in different sizes, either standard or custom-made, according to customer needs.

**PRE-BROYEURS MONOARBRE serie PMG**

La nouvelle série de pre-broyeurs GUIDETTI à "HAUTE EFFICACITÉ DE COUPE", grâce aux diverses combinaisons possibles entre puissance, diamètre grille, séparation magnétique, etc. peuvent travailler beaucoup de matériaux: câbles de cuivre ou d'aluminium, métaux non ferreux, caoutchouc, matières plastiques, bois, matériels composites, papier, etc. avec des productions variables de 300 à 3.000 kg/h. Pour ôter les parties ferreuses et protéger les tranchants dans les opérations successives de broyage, le système idéal est le transporteur GUIDETTI avec séparateur magnétique à roulement ou overband magnétique, disponible en différentes dimensions standard, ou bien sur la base des exigences du client.

**PRETRITURADORAS MONOEJE serie PMG**

La nueva serie de pretritadoras GUIDETTI garantiza un "EXCELENTE NIVEL DE CORTE", gracias a las varias combinaciones posibles entre potencia, diámetro parrilla, separación magnética, etc. Se pueden tratar una multitud de materiales: cables en cobre y aluminio, metales, excluyendo el hierro, goma, materias plásticas, madera, materiales compuestos, papel, et. La producción puede ir de 300 a 3000 kg/hora. Para eliminar las partes en hierro, y proteger el corte durante la trituración, GUIDETTI ofrece la solución ideal, la cinta transportadora con rodillo separador magnético o bien overband magnético. Está disponible en varias dimensiones estandar e incluso en dimensiones personalizadas para satisfacer las necesidades particulares del cliente.

**EINWELLEN - VORSCHREDDER, Serie PMG**

Die neue Serie von Vorschredder GUIDETTI mit "HOCHEFFIZIENTEM SCHNITT", dank der verschiedenen Kombinationen zwischen Leistung, Sieb-Durchmesser, magnetische Trennung, usw., können verschiedene Materialien verarbeitet werden wie z.B. Kupfer und/oder Aluminium-Kabel, Nichteisenmetalle, Gummi, Kunststoffe, Holz, Verbundstoffe, Papier, usw. Der Durchsatz ist variabel von 300 bis 3.000 Kg/Std. Um die Eisenteile zur Zerkleinerung einzubringen – und um somit die Klingen zu schützen –, ist ein ideales System das Förderband GUIDETTI mit Rollermagnetabscheider oder Überbandmagnet, das in verschiedenen Standardabmessungen oder auch nach Kundenanforderungen verfügbar ist.



Riciclaggio cavi elettrici e radiatori - Electric cables and radiators recycling



Riciclaggio RAEE e CAR FLUFF - W.E.E Recycling and CAR FLUFF



Riciclaggio metalli non ferrosi - Non-ferrous metals recycling



Riciclaggio materie plastiche - Plastics recycling



Separazione densimetrica a secco - Dry densimetric separation



Riciclaggio inerti e vetro - Aggregates and glass recycling

www.guidettisrl.comVia Salvi, 1 | 44045 Renazzo [FE] Italy | Tel. +39 051 6858511 | Fax +39 051 972099 | info@guidettisrl.com

Guidetti s.r.l. si riserva il diritto di apportare modifiche ai prodotti in qualsiasi momento, anche senza preavviso. È vietata la riproduzione, anche parziale, del materiale qui contenuto se non autorizzata.
 Guidetti s.r.l. reserves the right to make changes to its products at any time, including without notice. Unauthorised reproduction, including partial, of the contents of this document is forbidden.
 Guidetti s.r.l. se réserve le droit de modifier à tout moment les produits, même sans préavis. La reproduction, même partielle, du matériel contenu dans ce manuel est interdite, à moins d'une autorisation préalable.
 Guidetti s.r.l. se reserva el derecho a aportar modificaciones a los productos en cualquier momento, incluso sin preaviso. Está prohibida la reproducción, incluso parcial, del material aquí contenido si no ha sido previamente autorizada.
 Die Guidetti s.r.l. behält sich vor, jederzeit Änderungen auch ohne Vorankündigung an den Produkten vorzunehmen. Der auch teilweise Nachdruck ohne Genehmigung ist untersagt.

**GUIDETTI**
RECYCLING SYSTEMSproudly
made in italy

MACCHINE
PER IL RECUPERO
DIFFERENZIATO
DA SCARTI E
SFRIDI
INDUSTRIALI

MACHINES
FOR INDUSTRIAL
SCRAPS
RECYCLING

PMG
linewww.guidettisrl.com



In conformità alle norme CE.
Conform to CE rules.
Conformes aux réglementations CE.
Son conformes a las normas CE.
Conformit CE-regeln.

MECHANICAL VERSION

PMG E	Dimensioni - Dimensions - Medidas - Außenmaße [mm]							Peso Weight Poids Peso Gewicht	Potenza Installata Installed Power Puissance Installée Potencia Instalada Installierte Leistung	Produzione Production Production Producción
	A	B	B1	C	C1	D	E			
PMG 400 E	1560	4682	4945	2740	2035	1715	1660	980	1420 kg	12,5 kW (*)
PMG 600 E	1750	4660	4925	2720	2255	1820	2055	1275	1840 kg	20 kW (*)

(*) Variabile a seconda del tipo di materiale trattato. - Changeable according to the kind of processed material. - Variable selon le matériel traité. - Varia según la tipología del material tratado. - Variabel je nach der Typologie des behandelten Materials.

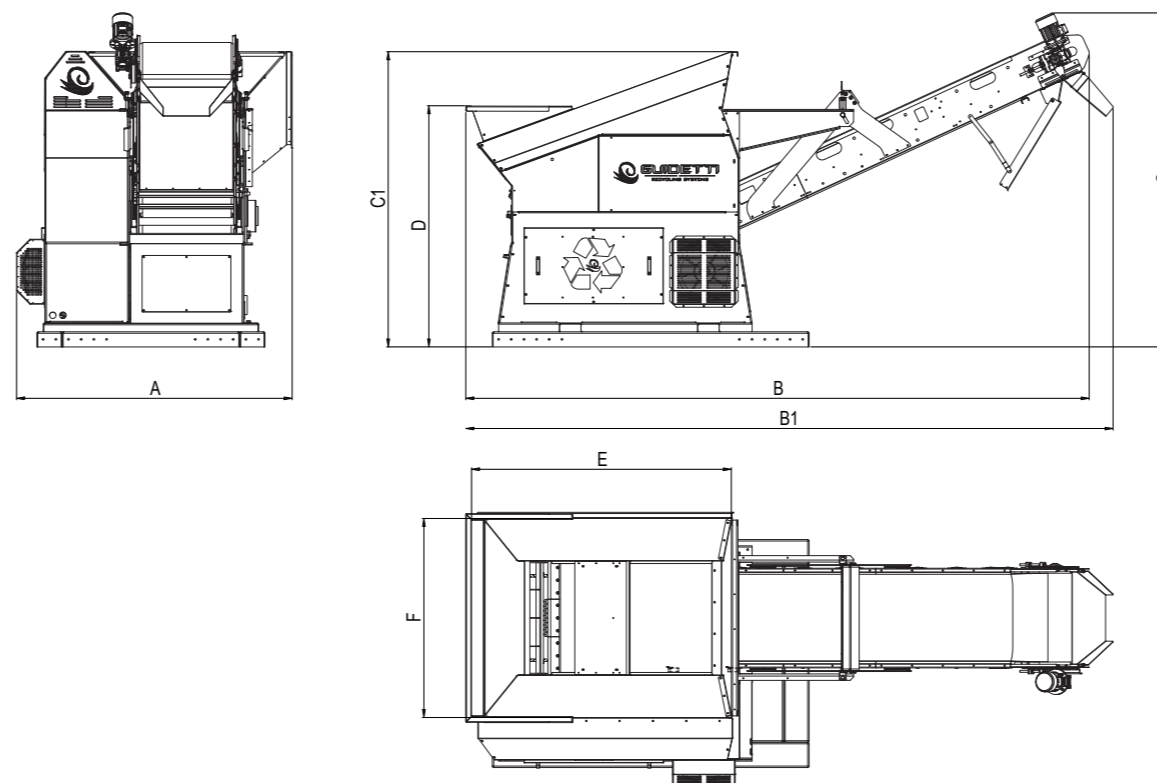

Turbo Giunto per ottimizzare le prestazioni.
Turbo connection to optimize performances.
Turbo joint pour optimiser les performances.
Conexión Turbo para optimizar el rendimiento.
Turbo-Verbindung um die Leistung zu optimieren.

HYDRAULIC VERSION

PMG H	Lunghezza Length Longueur Largo Lange	Larghezza Width Largeur Ancho Breite	Altezza Height Hauteur Altura Höhe	Peso Weight Poids Peso Gewicht	Potenza Installata Installed Power Puissance Installée Potencia Instalada Installierte Leistung	Produzione Production Production Producción
PMG 900 H	2110 mm	2070 mm	2245 mm	2840 kg	38,5 kW	(*)
PMG 1200 H	3560 mm	2300 mm	2540 mm	4550 kg		(*)
- Hydraulic Control Unit	2100 mm	1100 mm	1840 mm	1700 kg	78 kW	
PMG 1600 H	3895 mm	2516 mm	3129 mm	7850 kg		(*)
- Hydraulic Control Unit	3053 mm	1475 mm	1900 mm	/	132 kW	

(*) Variabile a seconda del tipo di materiale trattato. - Changeable according to the kind of processed material. - Variable selon le matériel traité. - Varia según la tipología del material tratado. - Variabel je nach der Typologie des behandelten Materials.

I dati tecnici sono indicativi e possono essere variati a scopo migliorativo senza preavviso. - The technical data are indicative and can be changed without previous notice. - Les données techniques sont indicatives et sujettes à modification sans préavis. - Los datos técnicos son indicativos y pueden variar sin previo aviso. - Die technischen Daten sind unverbindlich und können jederzeit ohne vorherige Ankündigung geändert werden.

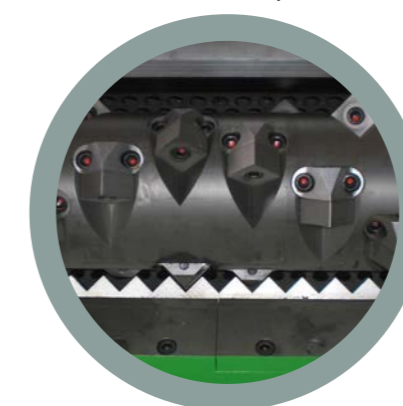

Supporto lama ad alta resistenza di facile sostituzione.
Long-lasting blade support, easy to replace.
Support de lame haute résistance, facile à remplacer.
Soporte de la cuchilla de alta resistencia, fácil de reemplazar.
Hohe Festigkeit Messer- Halter leicht zu ersetzen.

PMG 1200 H



Centrale idraulica insonorizzata.
Soundproofed hydraulic system.
Distributeur hydraulique insonorisé.
Central hidráulica insonorizada.
Schalldichtes hydraulisches Steuergerät.



Esempio di linea automatica.
Example of automatic line.
Exemple de ligne automatisée.
Ejemplo de línea automática.
Beispiel von automatischer Anlage.

- 1 PMG 400 E
- 2 NT 400
- 3 SINCRO 415 eko